

User manual

Wood's Condensate Pump module WDP-01



Wood's[®]

Visit our website www.woods.se for:
Usage advice, updated brochures, trouble shooter and service information.

CUSTOMER CARE AND SERVICE

Always use original spare parts.

When contacting our Authorised Service Centre, ensure that you have the following data available: Model number, receipt and serial number.

Warning / Caution-Safety information.

General information and tips.

Environmental information.

Subject to change without notice.

Please read this manual carefully before installing and using your Wood's product.



www.woods.se

A



B

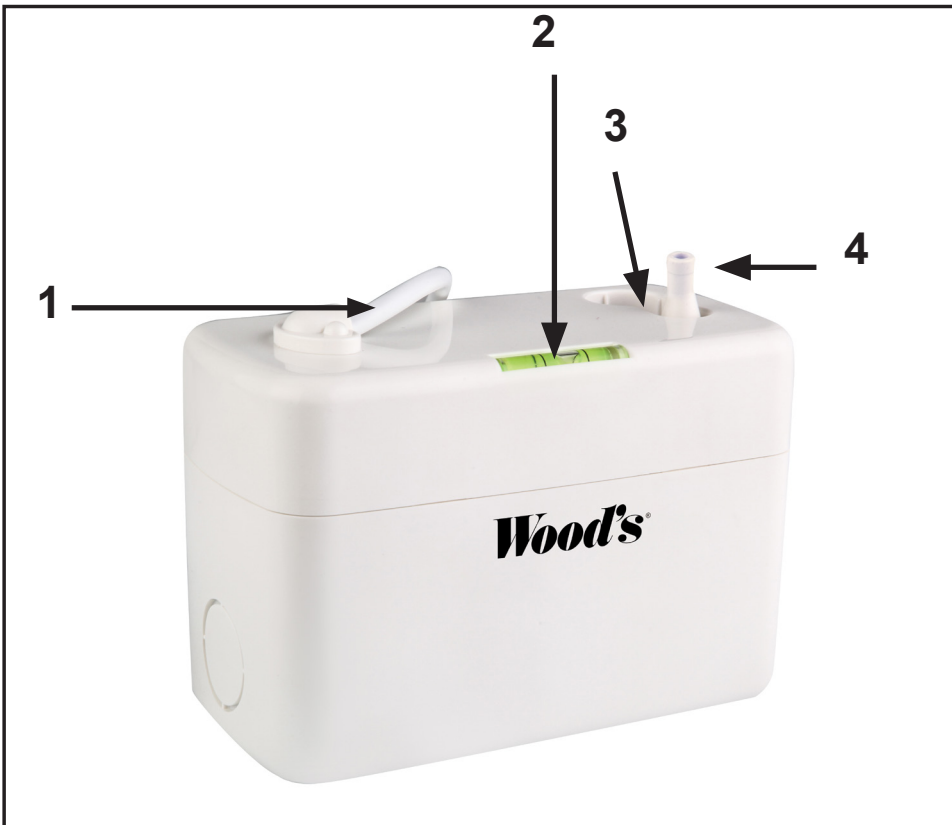

C

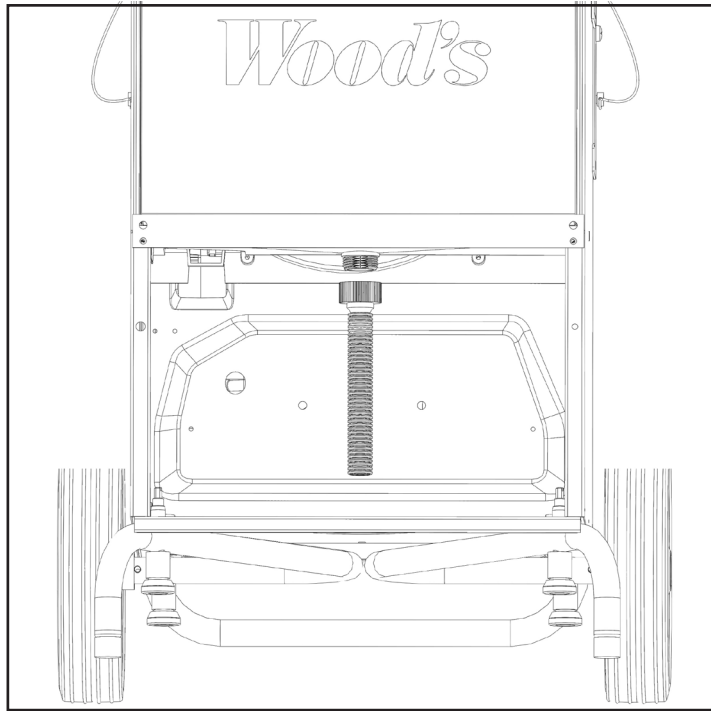

D1

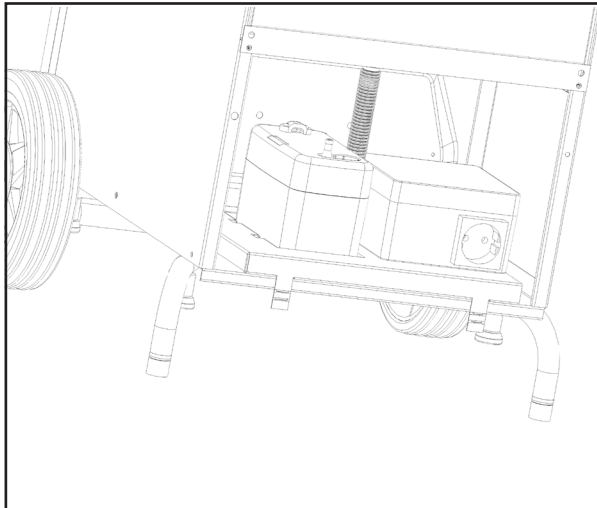

D2

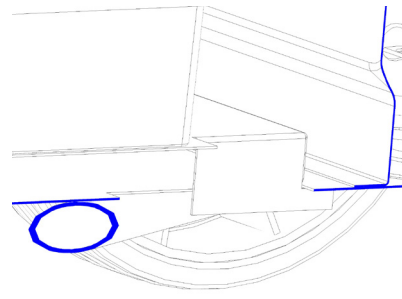

E

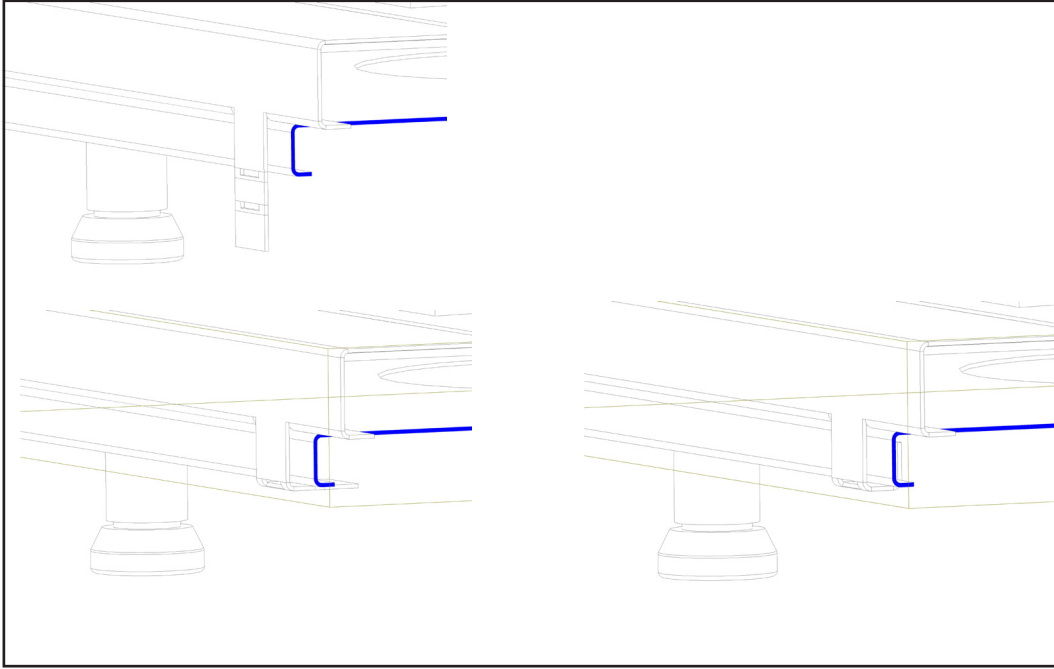

F

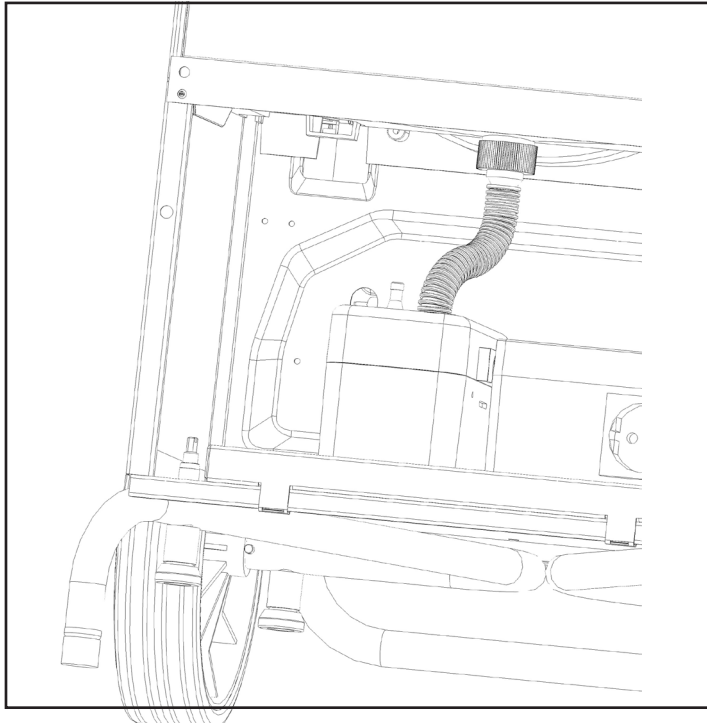

G 1



G 2



H 1



H 2



H 3



H 4



1. Important notes

Thank you for buying Wood's Condensate Pump WDP-01. This manual provides instructions for proper installation. It is important that you follow these instructions carefully.

1. Important notes

1. Before installing pump kit, ensure that the de-humidifier is not connected to a power outlet.
2. This kit is intended only for use with Wood's de-humidifiers
3. Risk of electric shock. This pump kit is non submersible.
marne areas.
4. If the cord, connection box or pump unit of this kit is damaged, the damaged part must be replaced by trained personnel using replacement parts available from the manufacturer.
5. Installation must be performed according to this manual
6. The pump must always be in a horizontal position when connected to a power outlet

2. PRODUCT DESCRIPTION

Product description

Picture A. Pump module WDP-01

Pump connections

Picture B

- 1) Power supply
- 2) Level
- 3) Inlet Port
- 4) Outlet Port

3. Technical specification

Model	WDP-01
Voltage	100-230V~/50-60Hz
Discharge Head	10m
Rated	Non continuous
Flow Rate	40L/h
Tank Capacity	200ml
Mini splits up to	15KW(45,000tu/hr)
Sound Level	21dB(A)
Ambient Temperature	2°C~50°C
Power Consumption	3W
Safety Switch	NC 3A-250V

4. Installation dehumidifier Pump module

Installing Wood's dehumidifier Pump

Module

Picture C

Attach hose and hose adapter to drain tray.
Tighten adapter to achieve a tight seal

Picture D

D1. Position pump unit. Observe the position of front tabs in relation to cut-outs in bottom plate of dehumidifier.

D2. The pump unit might need to be tilted slightly towards the front of the de-humidifier to properly enter the cutouts.

Picture E

Secure the pump unit by bending, by hand or using hand tools, the two front tabs around the de-humidifier bottom plate flange

Picture F

Connect the hose to the waterpump top inlet. Make sure there are no kinks in the hose when finished

Picture G1 and G2

Installed pump module WDP-01

5. Installation the pipe on the pump

Wood's pipe installation

Picture H 1

The contents of the package

- 1) Manual 1pcs
- 2) Plastic joint 1pcs
- 3) Corrugated pipe 1pcs
- 4) Outlet pipe assembly 1set

Picture H 2

Connect plastic joint and corrugated pipe

Picture H 3

Connect the water outlet with the outlet pipe assembly and hold it with a hoop.

Picture H 4

This is how the product looks pre-assembled

6. Service

If the unit requires servicing, you must first contact your local retailer. Proof of purchase is required for all warranty claims.

7. Troubleshooting

Problem	Cause	Action
Pump runs all the time	1. Installation is not horizontal.	1. Adjust the tank make it level.
	2. There is sludge inside tank.	2. Clean the inside of tank and float.
Pump makes loud noise	1. The water is siphoning back in the pump.	Check whether the outlet pipe is lower than pump thus result in siphoning, raise the condensate pump position.
Pump doesn't start	1. Installation is not horizontal.	1. Adjust the tank, check water level.
	2. The power can't reach pump.	2. Check power supply.
	3. The voltage isn't correct.	3. Check the voltage.

WARNING Please note the distinction between the power line and signal line, wrong wiring will result in damage to the drain pump and ensure consistent product identification voltage.

8. Maintenance

Pump

Flush the pump through with anti-bacterial wash and clean both filters every 6 months or more often if required to avoid sludge build up. Clean the unit with a soft moist cloth. Do not use solvents or strong cleaners as this might damage the surface of the unit.

9. Warranty

For consumer use the warranty is limited to 2 years from the date of purchase

The warranty is considered valid only if receipts of original purchase can be produced and only if the product has been installed and used in accordance with the instructions given in this manual.

The warranty does not cover any damage caused by improper handling of the product.

For commercial use the warranty is limited to 1 year from the date of purchase



This marking indicates that this product should not be disposed with other household wastes throughout the EU. To prevent possible harm to the environment or human health from uncontrolled waste disposal, recycle it responsibly to promote the sustainable reuse of material resources. To return your us device, please use the return and collection systems or contact the retailer where the product was purchased. They can take this product for environmental safe recycling.

Contact:

Wood's is marketed and distributed by Woods TES Sweden AB

Maskingatan 2-4
441 39 – Alingsås, Sweden

+46(0)31-761 36 10
www.woods.se
info@woods.se

Wood's[®]